

Biologics manufacturer
seeks 1000L break tank for
accurate control of WFI
delivery to inline dilution skid



Dennis Hodgson

Biotech Product
Manager,
Agilitech Group

Mason Pawsey

Biotech Operations
Manager,
Agilitech Group

Trey Peters

Lead Biotech Mechanical
Designer,
Agilitech Group

Dr. Michael J Morgan, PhD

Chief Innovation Officer &
Executive Director of Biotech,
Agilitech Group

Situation

A recognized world leader in contract drug manufacturer was in need of a stable supply of up to 1000L of WFI to their 1" single-use inline dilution skid, without interference from a fluctuating facility WFI loop.

As a CDMO, our customer was looking to invest in equipment that could help them serve their current and future customers, regardless of what their process may require.

While their existing WFI loop could provide water at various drops throughout the building, having a portable break tank that could deliver up to 1000L on demand would enable more efficient use of their cleanspace - critical for a CDMO that wants to maximize their throughput while maintaining accuracy when preparing critical buffers.

Approach

In search of a single-use solutions provider that could meet their engineering needs, the company leveraged their internal networks to discover that Agilitech was up to the challenge. An initial discussion about the expectations of this project, the challenges, and the requirements helped Agilitech design a portable 1000L single-use tote specifically to meet the company's needs.

Agilitech paired decades of mechanical engineering expertise with cutting-edge laser welding technology to design and manufacture a robust yet portable tote that could accurately weigh the contents within 0.02% error.

By using Eilersen digital capacitive load cells, we were able to provide a tote that was not only safe for one person to move, but also extremely robust. Movement of the tote does not require any "lock-out plates" and calibration is not required after moving.

We also wanted to integrate a bracket onto the tote to hold a 10" PES cartridge filter. This filter would come gamma irradiated and pre-installed into the outlet tubing connected to the 1000L single-use bag that we would be providing for the tote.

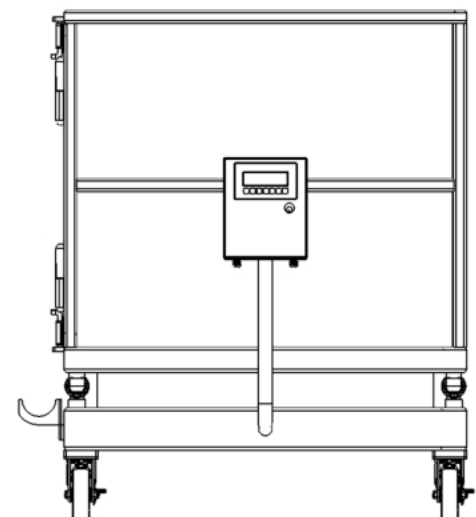
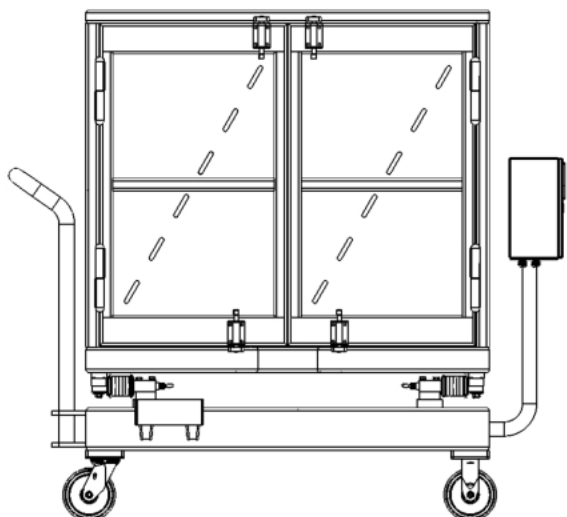
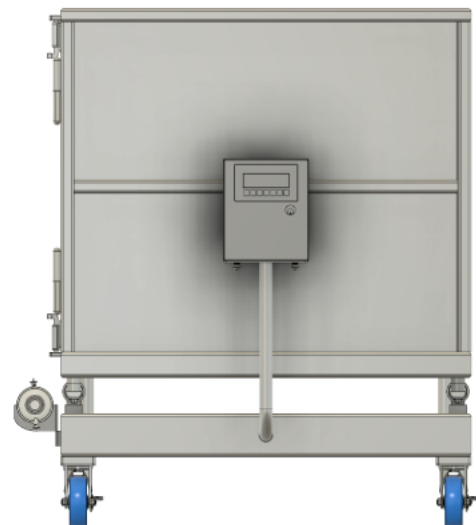
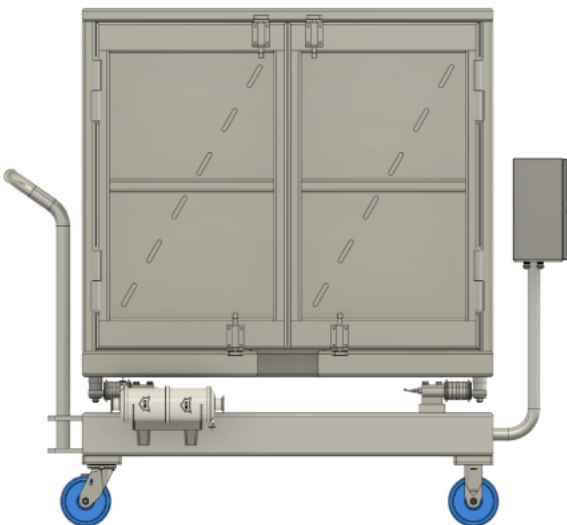

Solution

Agilitech understands the importance of process optimization in the dynamic world of contract drug manufacturing. CDMOs have to invest in equipment that is versatile and adaptable to the many current and potential future processes that their customers expect them to support.

Forward-thinking component selection helped future-proof this tote by leveraging an Eilersen indicator that supports multiple communication protocols, making it trivial to integrate the tote into a process skid or facility control system in the future.

In addition to the instrumentation selection, the material choices for the tote were also essential. Made from a strong, corrosion-resistant stainless steel alloy, the tote is robust yet surprisingly portable for its size.

Agilitech leveraged laser beam welding to reduce the amount of finishing on the tote, which reduced the overall project cost and lead time, all while maintaining an excellent, cleanable surface finish.

The 1000L tote, designed to hold up to 1000 kg of WFI, was calibrated by an ISO/IEC 17025-2017 recognized organization to be within 0.02% accuracy at 1250 kg.



The impact of a single-use solutions partner

The biotech industry, especially CDMOs, require flexible operations and equipment that supports that flexibility. This 1000L tote, used to provide a steady supply of WFI to an ILD skid (also designed and manufactured by Agilitech), helps support a variety of dilution and buffer preparations for a multitude of processes.

By choosing Agilitech to provide the 1" single-use inline dilution skid and 1000L WFI tote, our customer was able to leverage decades of mechanical, electrical, automation, and process engineering prowess to ensure their facility was equipped with the technology it needed to be a pioneer in the contract drug manufacturing space. This commitment to advanced technologies makes this customer the preferred choice of pharmaceutical companies worldwide.

Ask us how we can partner with you on pioneering solutions to your unique challenges.



6-inlet 1" single-use ILD skid capable of diluting up to 40 LPM at a 1:10 ratio, with automatic pH and conductivity control; paired with the 1000L WFI tote.

About Agilitech

We believe in the power of science and medicine to solve health problems and make lives better – today and in the future. As a pioneering partner to the biotech industry, we help to drive this progress by designing and implementing state-of-the-art equipment for biotech labs through to full-scale manufacturing, along with providing game-changing bioprocess engineering and automation services.

In a fast-moving industry that is constantly evolving, we have the flexibility and experience to tailor our offerings to the specific requirements of each and every customer. We ask the right questions and take the time to understand both what you're doing and where you're going, so that we can offer fresh perspectives and develop custom solutions to real problems.

Our goal is to exceed your expectations, to offer you the full benefit of our industry insights and expertise and to establish a long-term business relationship built on trust and proven results.

Agilitech Corporate Headquarters:
8800 Crippen Street
Bakersfield, CA 93311

Customer Support:
661.381.7950
info@agilitech.bio

Service & Repair:
661.381.7950
service@agilitech.bio

A RADICAL & TRANSFORMATIVE APPROACH



TRANSFORMATIVE
BIOPROCESS
PRODUCT
DESIGN



COLLABORATIVE
DESIGN &
CO-CREATION



UNMATCHED
FLEXIBILITY



BRAND
AGNOSTIC
FOR SEAMLESS
INTEGRATION



THE FREEDOM
OF OPEN
PLATFORM